

Installation

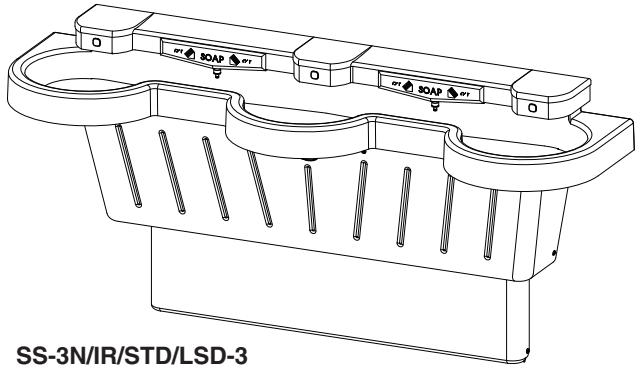

SS-3N/IR/STD/LSD-3

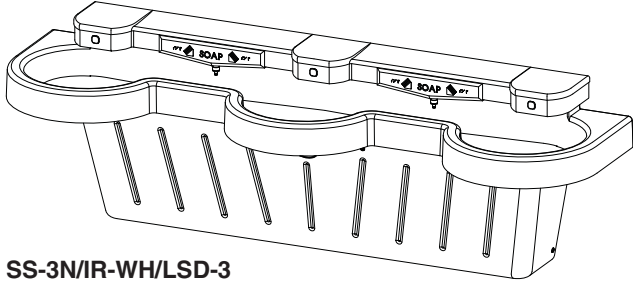

SS-3N/IR-WH/LSD-3

SS-3N/IR/STD SS-3N/IR-WH

Express® Lavatory System SS-Series

Express Lavatory Systems are ADA and TAS compliant

U.S. Pat. Nos. 5,611,093, 5,369,818, D398,969

Other Patents Pending

Table of Contents

| | |
|---|------|
| Pre-Installation Information | 2 |
| Components | 3 |
| Supplies Required | 4 |
| Dimensions | 4-5 |
| Rough-Ins | 6 |
| Installation | 7-10 |
| Sensor Assembly and Solenoid Valve Access | 11 |
| Solenoid Valve Troubleshooting | 12 |
| Navigator® Mixing Valve Troubleshooting | 13 |
| Stop Valve Troubleshooting | 14 |
| Cleaning and Maintenance for Terreon® | 14 |
| Soap Dispenser Maintenance | 15 |



! IMPORTANT! !

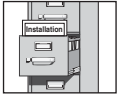

Read this entire installation manual to ensure proper installation. When finished with the installation, file this manual with the owner or maintenance department. Compliance and conformity to local codes and ordinances is the responsibility of the installer.



Separate parts from packaging and make sure all parts are accounted for before discarding any packaging material. If any parts are missing, do not begin installation until you obtain the missing parts.

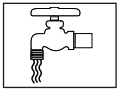

Make sure that all water supply lines have been flushed and then completely turned off before beginning installation. Debris in supply lines can cause valves to malfunction.

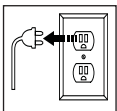

Turn OFF electrical power to the electrical outlets, then unplug all electrical units prior to installation. Electrical power MUST remain off until unit and optional water heater have been plumbed. After installation is complete, turn on the water supply first, then turn on the electrical power.

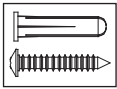

Hardware supplied by installer must be appropriate for wall construction. Wall anchors must have a minimum pull-out rating of 1,000 lbs. Follow appropriate dimensions for standard or juvenile height based on configuration and required rim height. Overtightening fasteners can damage the Terreon® material. Use caution when tightening bowl and sprayhead fasteners.



Product warranties may be found in the "Products" section on our Web site at bradleycorp.com.

Special Note for Sprayhead/Bowl retrofit

to retrofit new SS-3N sprayhead onto existing SS-3 bowl

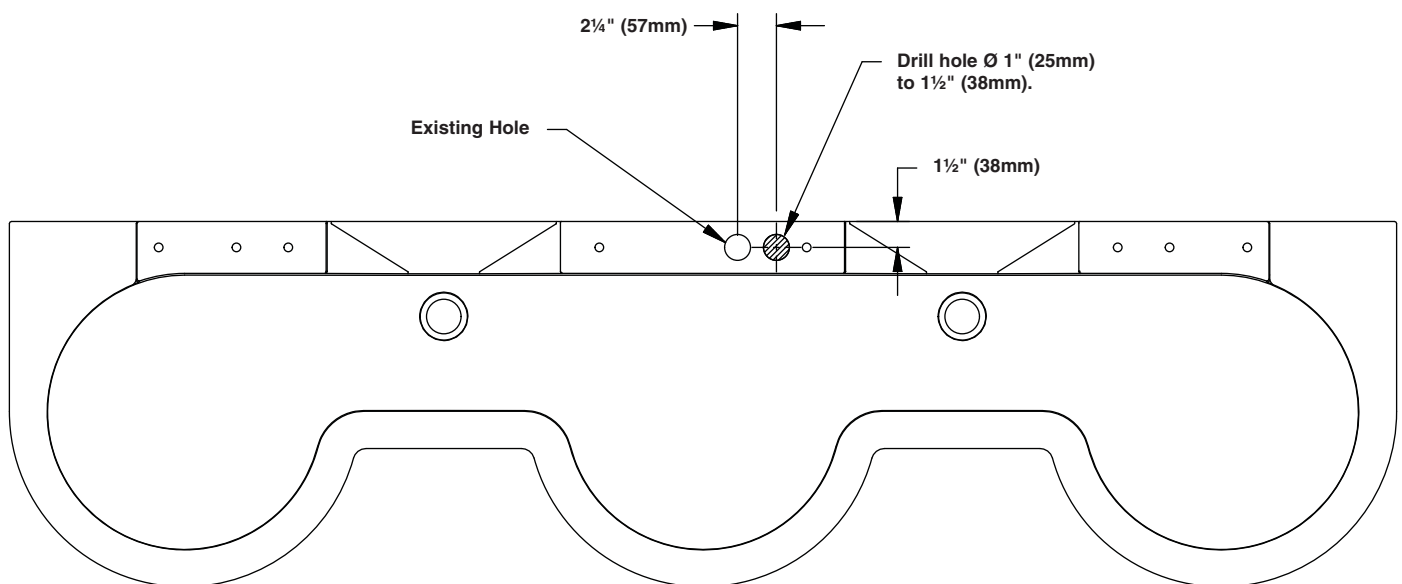

Components

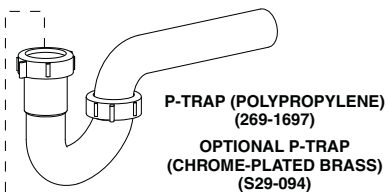
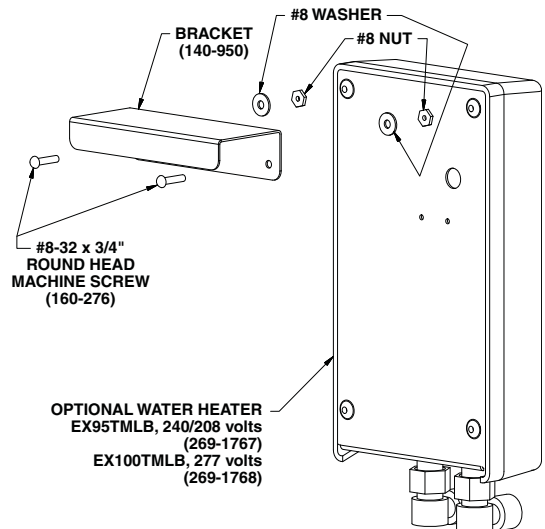
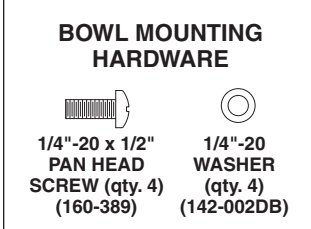
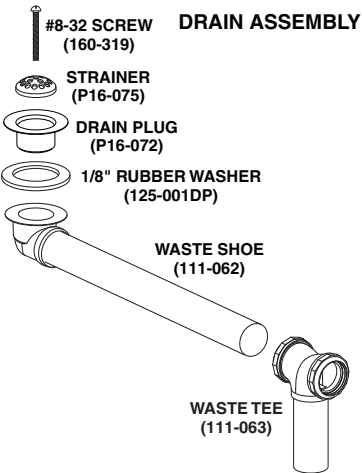
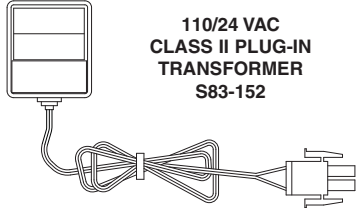
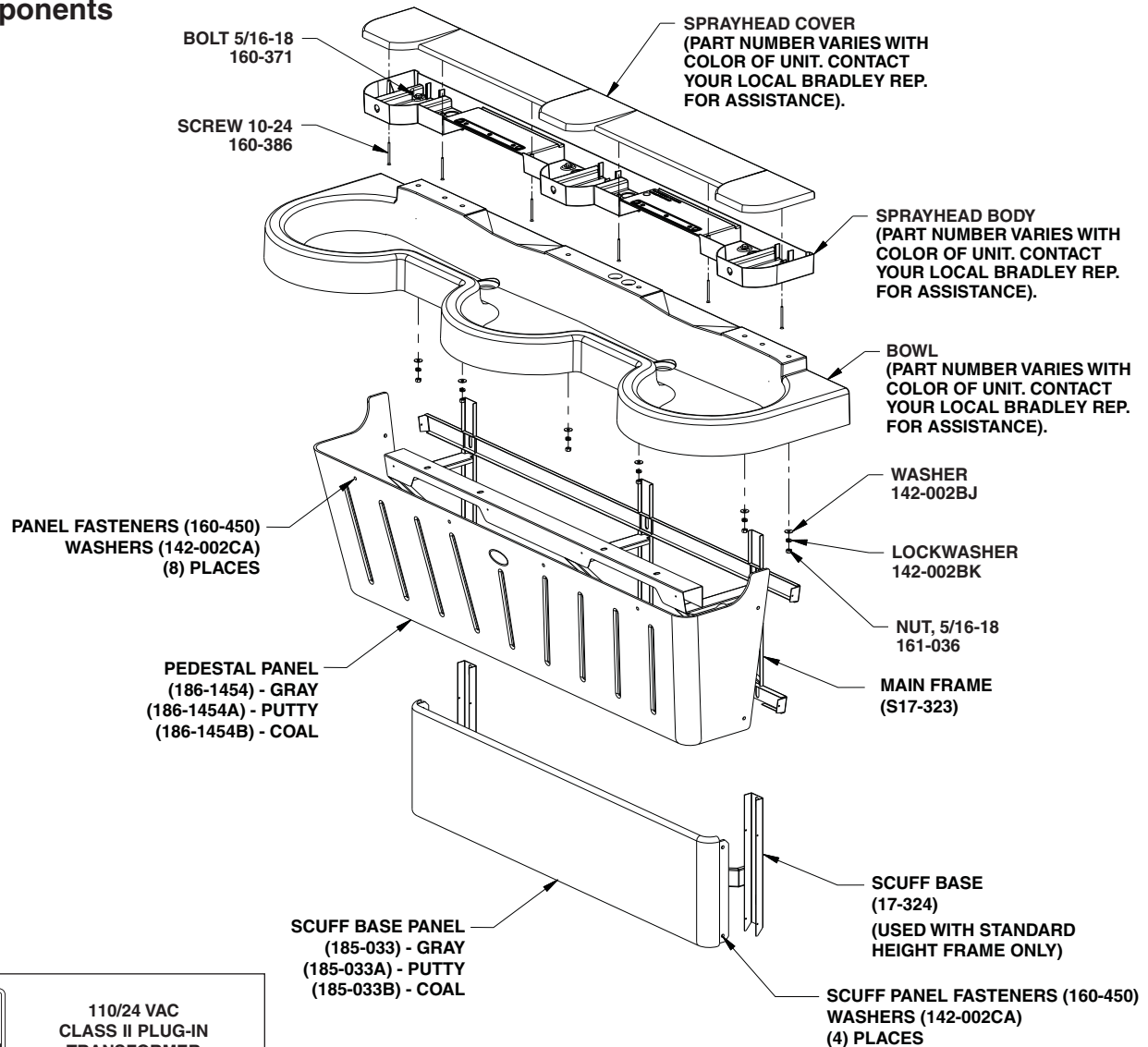

Supplies Required:

- (8) 3/8" wall anchors, bolts and 1" min. O.D. washers to mount main frame and bowl to wall (minimum pull-out rating of 1,000 lbs.)
- STD. HEIGHT ONLY: (2) 3/8" wall anchors, bolts and 1" min. O.D. washers to mount scuff base to wall
- 1/2" nominal copper tubing for hot and cold supplies and 1 1/2" NPT drain piping
- 110 volt GFCI protected electrical outlet for 1110/24 VAC plug-in transformer (supplied)
- OPTIONAL: 240/208-volt or 277-volt electrical box for electric tankless water heater

Dimensions - Front and Top Views

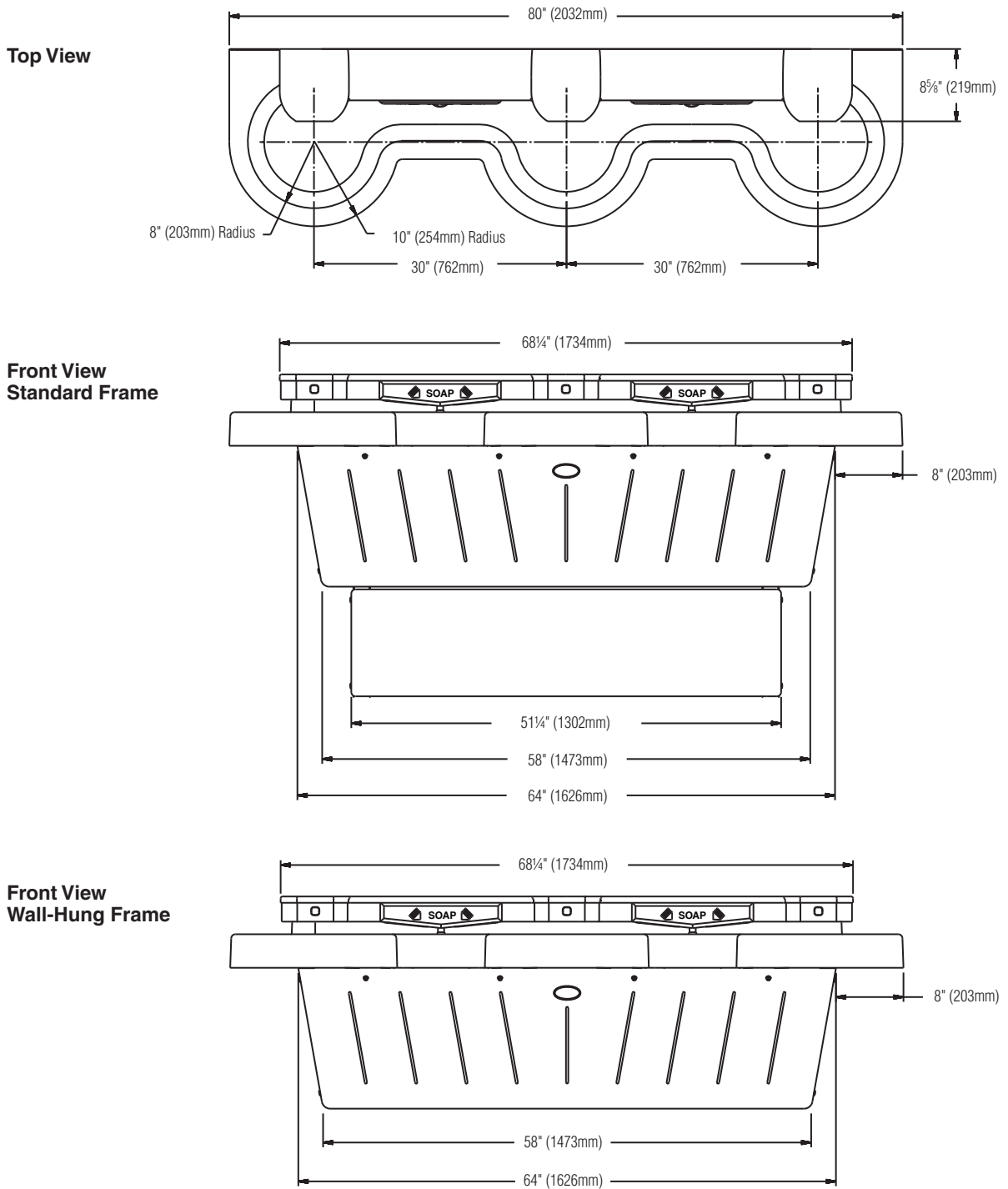

Dimensions - Side Views

Standard Height

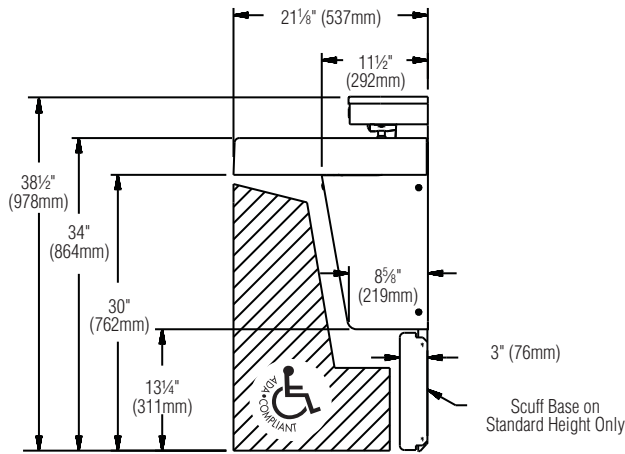

Wall Hung Mounted at Standard Height

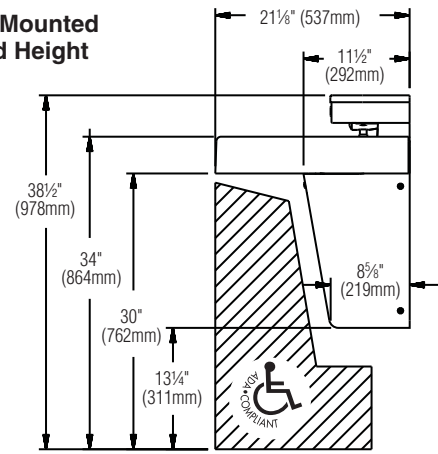

Wall Hung Mounted at Juvenile Height Ages: 6 through 12

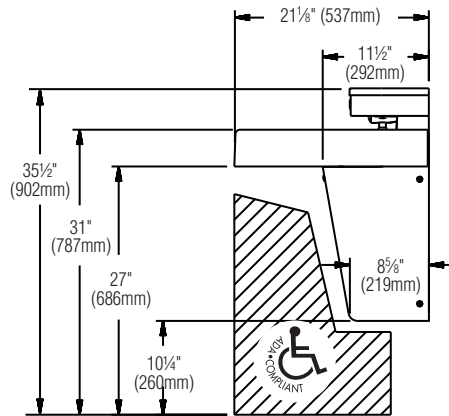

Wall Hung Mounted at TAS Height Grades: 6 through 8 or 9

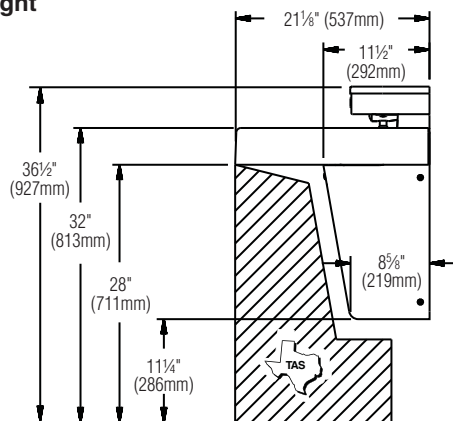

Wall Hung Mounted at TAS Height Grades: Pre-K through 5 or 6

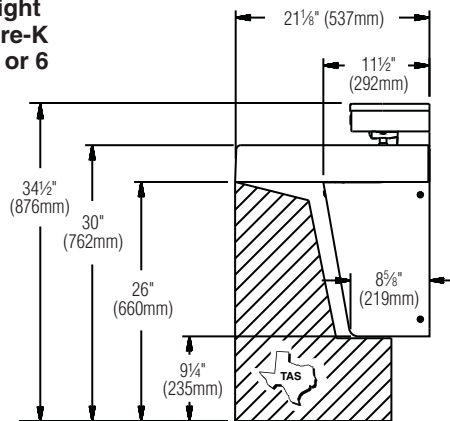

1 Rough-Ins

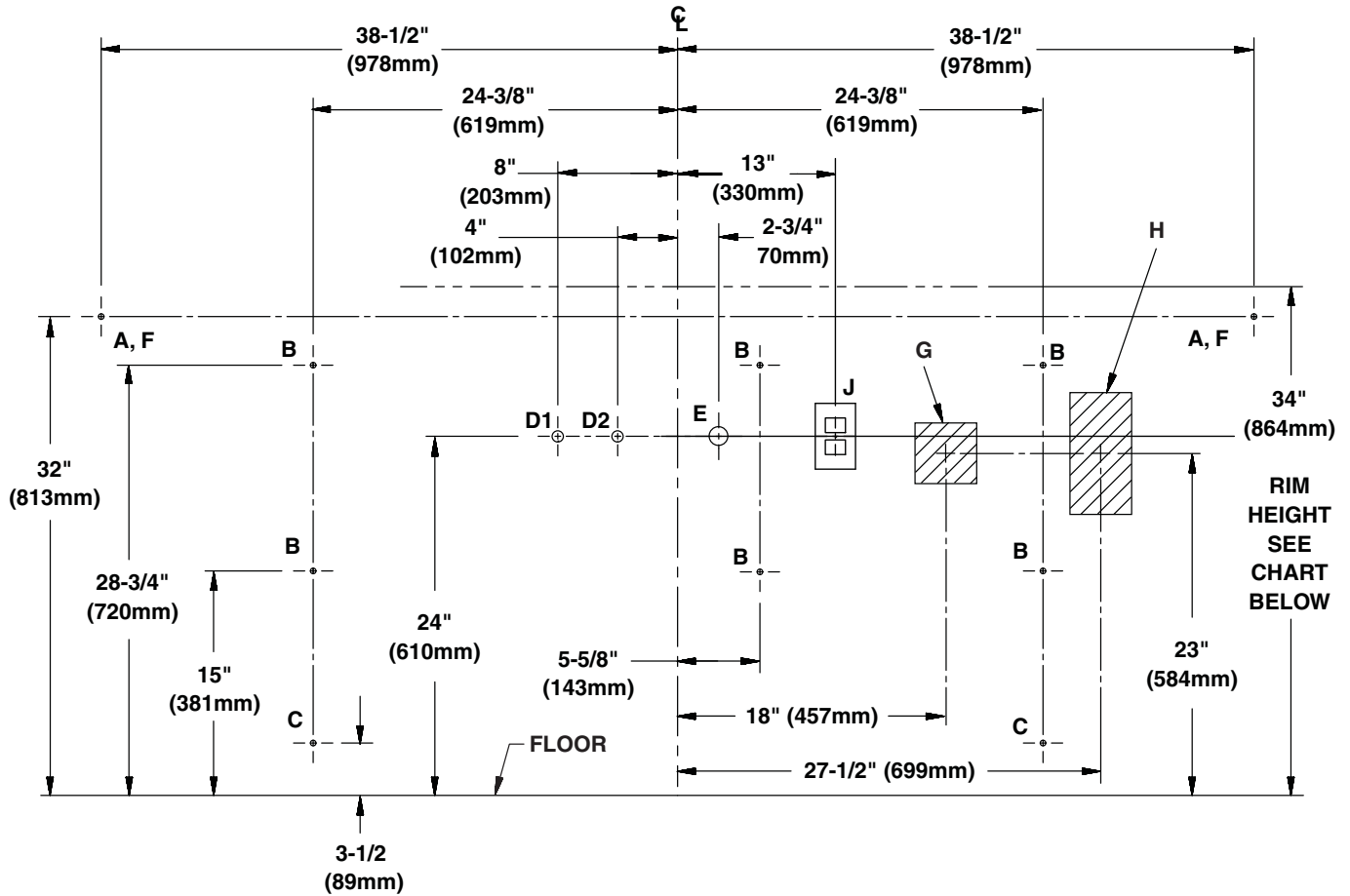

| CODE | DESCRIPTION | QTY. |
|------|---|------|
| A | 3/8" Wall Anchors with a minimum pull-out force of 1,000 lbs. for Bowl | 2 |
| B | 3/8" Wall Anchors with a minimum pull-out force of 1,000 lbs. for Mainframe | 6 |
| C | 3/8" Wall Anchors for Base Frame, Standard Frame option only, minimum pull-out force not required | 2 |
| D1 | 1/2" nominal copper tubing for Cold Supply, stub-out 2" from wall | 1 |
| D2 | 1/2" nominal copper tubing for Hot or Tempered Supply, stub-out 2" from wall | 1 |
| E | 1 1/2" NPT Drain, stub-out 2" from wall | 2 |
| F | On the bowl back, measure the distance between the 3/4" bowl mounting holes. Divide this measurement in half. Measure and mark this dimension on the wall to the left and the right of the centerline. Install two 3/8" wall anchors with a minimum pull-out rating of 1,000 lbs (supplied by installer) at locations marked. | 2 |
| G | Water Heater Option #1: Rough-in appropriate electrical supply per local code (recommended location for 240/208v or 277v electrical box [4" long x 4" wide x 8" high] shown) | 1 |
| H | Water Heater Option #2: Rough-in appropriate electrical supply per local code (recommended location for 240/208v or 277v electrical box [4" long x 4" wide x 4" high] shown) | 1 |
| J | 110v GFI Protected Electrical Outlet | 1 |

| RIM HEIGHT | VERTICAL HEIGHT ADJUSTMENTS FOR CODES A-E, H, C and W | FIXTURE STYLE |
|------------|---|----------------------------------|
| 34" | None | Standard Height |
| 34" | None | Wall-Hung |
| 32" | Subtract 2" | TAS, Grades 6 through 8 or 9 |
| 31" | Subtract 3" | Juvenile Height |
| 30" | Subtract 4" | TAS, Pre-K through Grades 5 or 6 |

2 Mount Frame to Wall



Anchoring the frame to a wall that is not flat may cause the frame to bend, making it difficult to reinstall the access panels. If necessary, use shims to compensate for wall distortion.

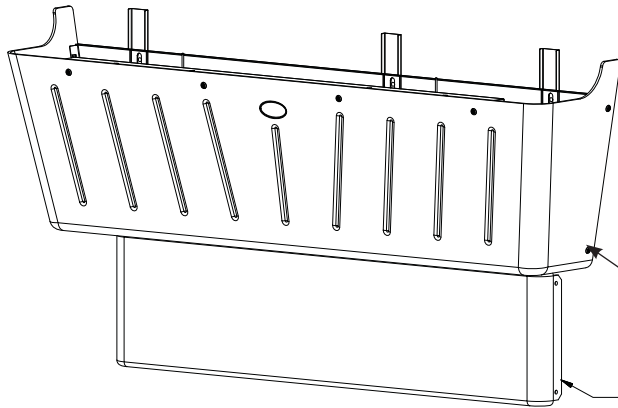

A Using a T20 torx key, remove the fasteners securing the access panel to the main frame, and remove the panel.

SCUFF PANEL
STANDARD HEIGHT
FRAME ONLY

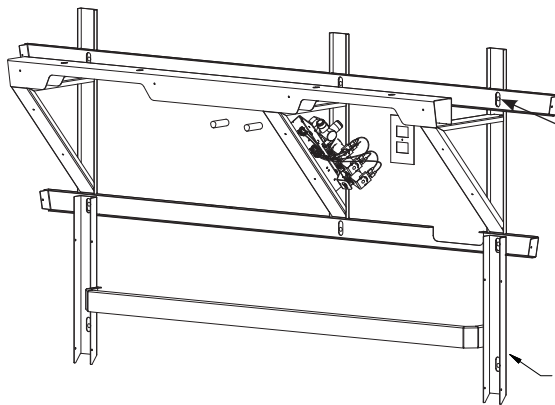

B

Once you have positioned the frame such that it is level and flat against the wall or shimmed, mount the frame to the wall at six places using $\frac{3}{8}$ " bolts and 1" min. O.D. washers.

NOTE: When mounting the standard height frame, mount the scuff base to the wall at the same time using two additional $\frac{3}{8}$ " bolts and washers.

SCUFF BASE FRAME
STANDARD HEIGHT
FRAME ONLY

3 Install Bowl



The sprayhead body has slotted holes for adjusting the fit-up with the bowl and wall.

For clarity, the scuff base frame and drain are not shown. Turn the tailpiece down to its proper position before installing the bowl.

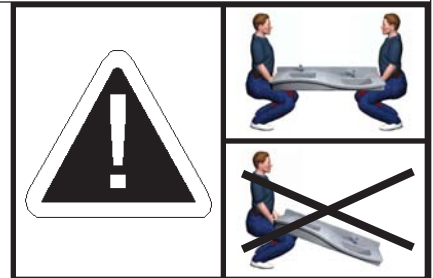

A Attach the bowl to the frame with $\frac{1}{4}$ "-20 x $\frac{1}{2}$ " pan-head screws and washers. Do not tighten.

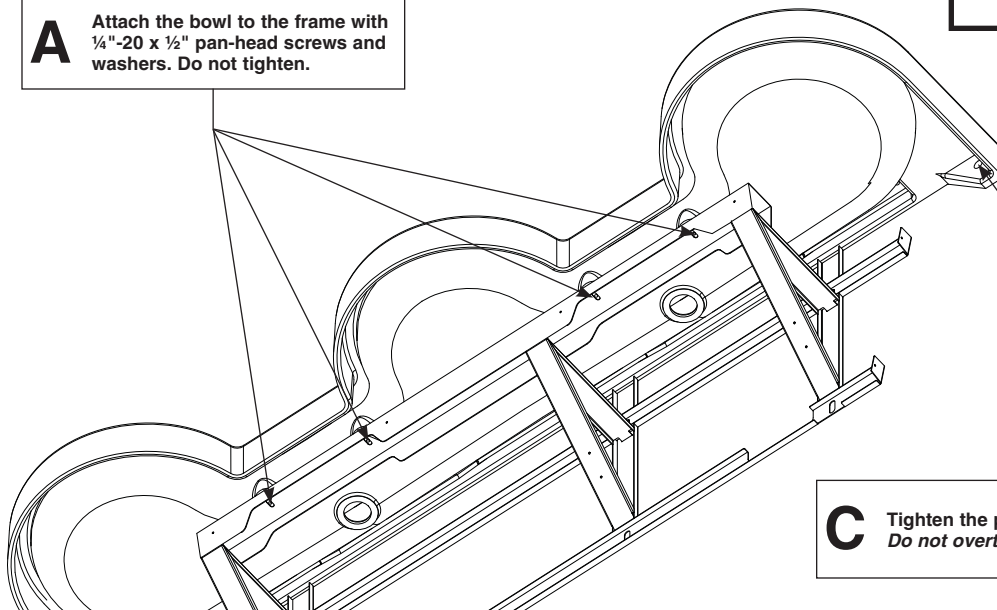

B

Secure the bowl to the wall anchors with $\frac{3}{8}$ " bolts and 1" min. O.D. washers, two places. Do not overtighten.

C

Tighten the pan-head screws Do not overtighten.

4a Connect the Supply — Hot and Cold Supply



The letter "H" on the Navigator Mixing Valve indicates hot water supply inlet.

C Connect one end of each hose to the Navigator valve (one on the hot side, one on the cold side).
Connect the other swivel end to the stop valves.

A Loosen but do not remove the two mounting screws holding the valve bracket to the frame.
Slide the valve bracket up and lift it from the frame.

B Attach the stops to the hot and cold water wall stub-outs.

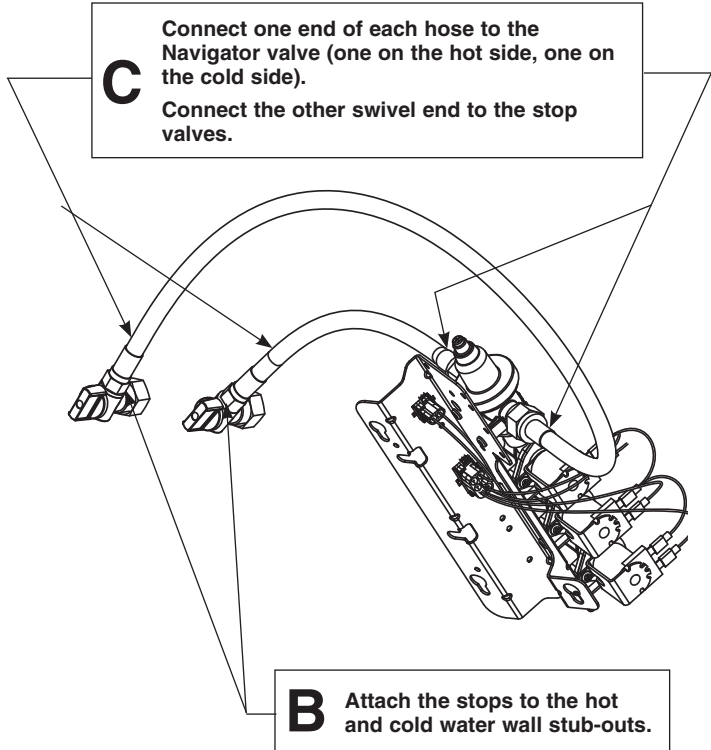

4b Connect the Supply — Single Tempered Supply

C Connect one end of flexible hose to the tempered line adapter.
Connect the other swivel end to the stop valve.

A Loosen but do not remove the two mounting screws holding the valve bracket to the frame.
Slide the valve bracket up and lift it from the frame.

B Attach the stop to the tempered wall stub-out.

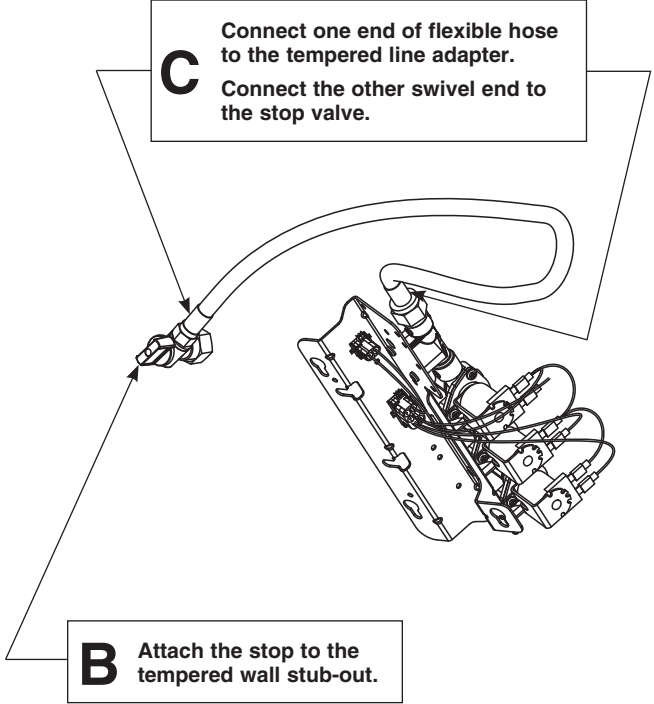

5 Install the Drains

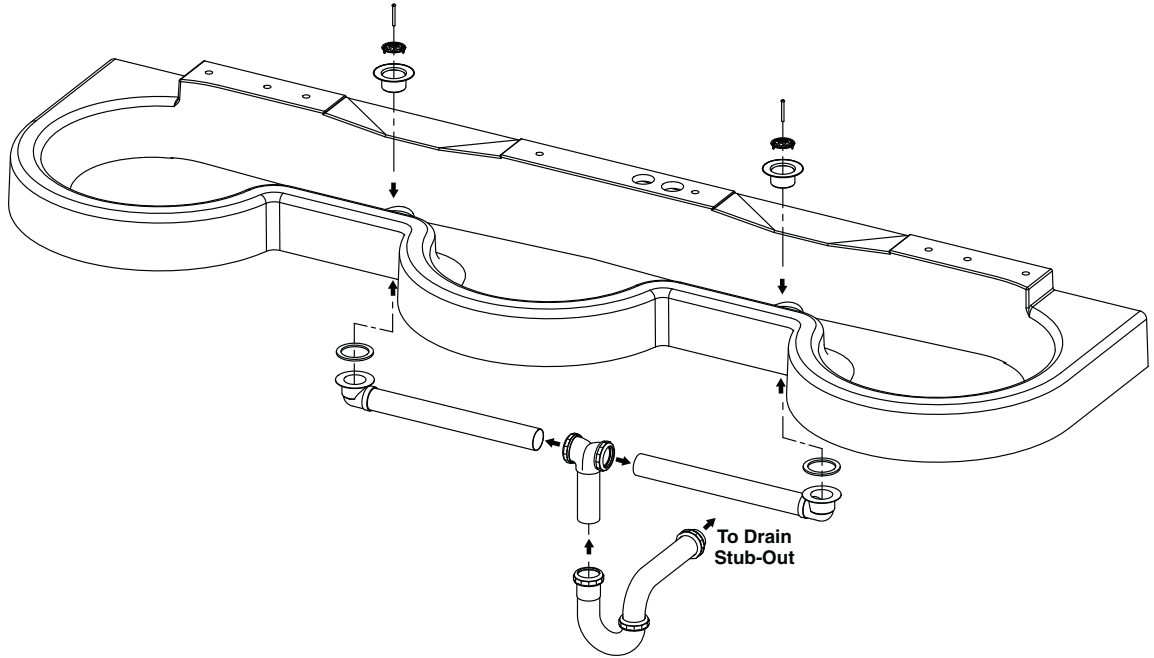

6 Optional Electric Tankless Water Heater



240/208 or 277 voltage is required for hot water heater. Refer to the installation manual provided with the hot water heater for further installation information.

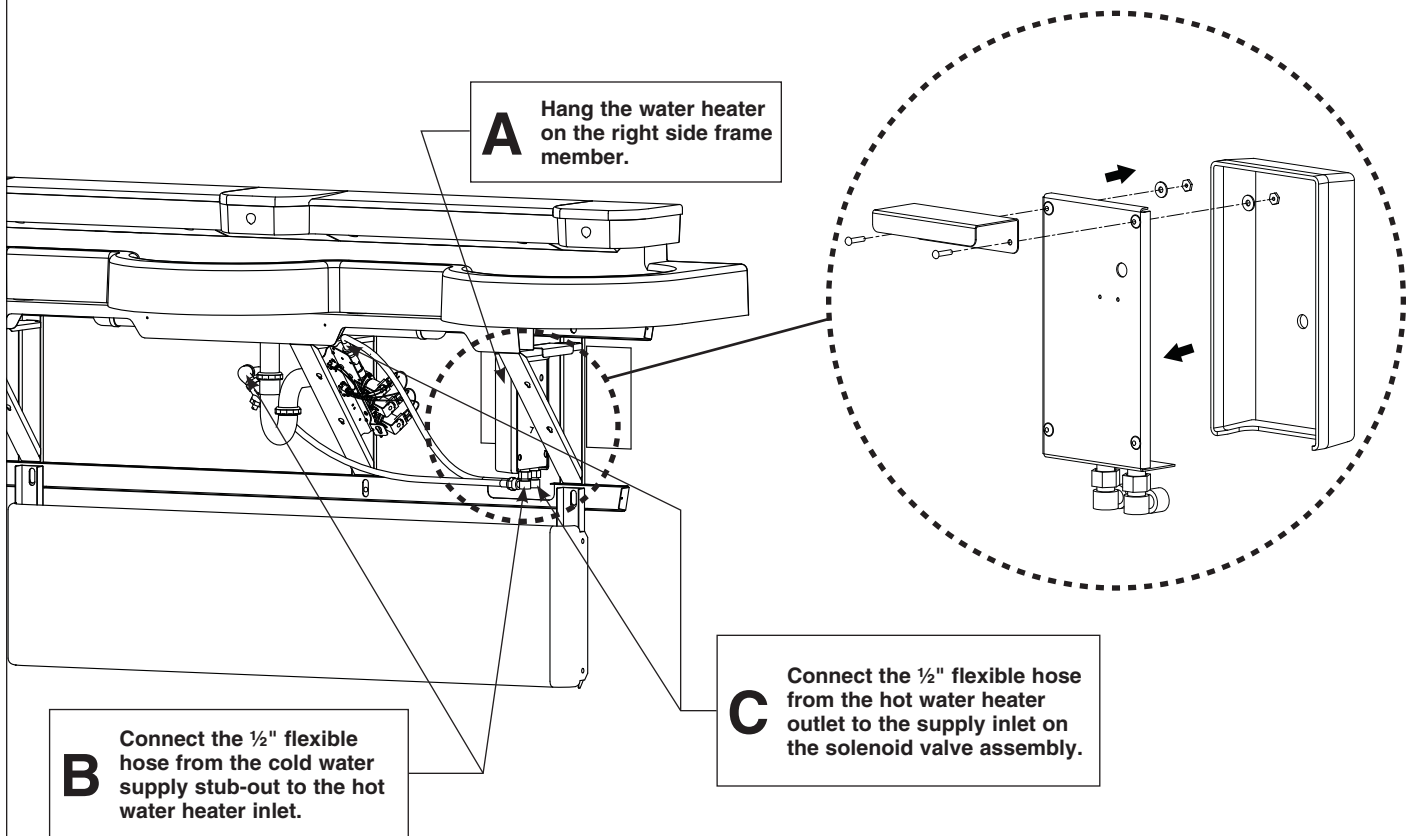

7 Connect Electrical and Sprayhead Supplies

WARNING: The Express® control must be connected with the 24 VAC Class II transformer provided. Connections to 110 VAC can cause personal injury and will result in damage to the electronics. Connection of leads other than shown may cause permanent damage to the sensor.

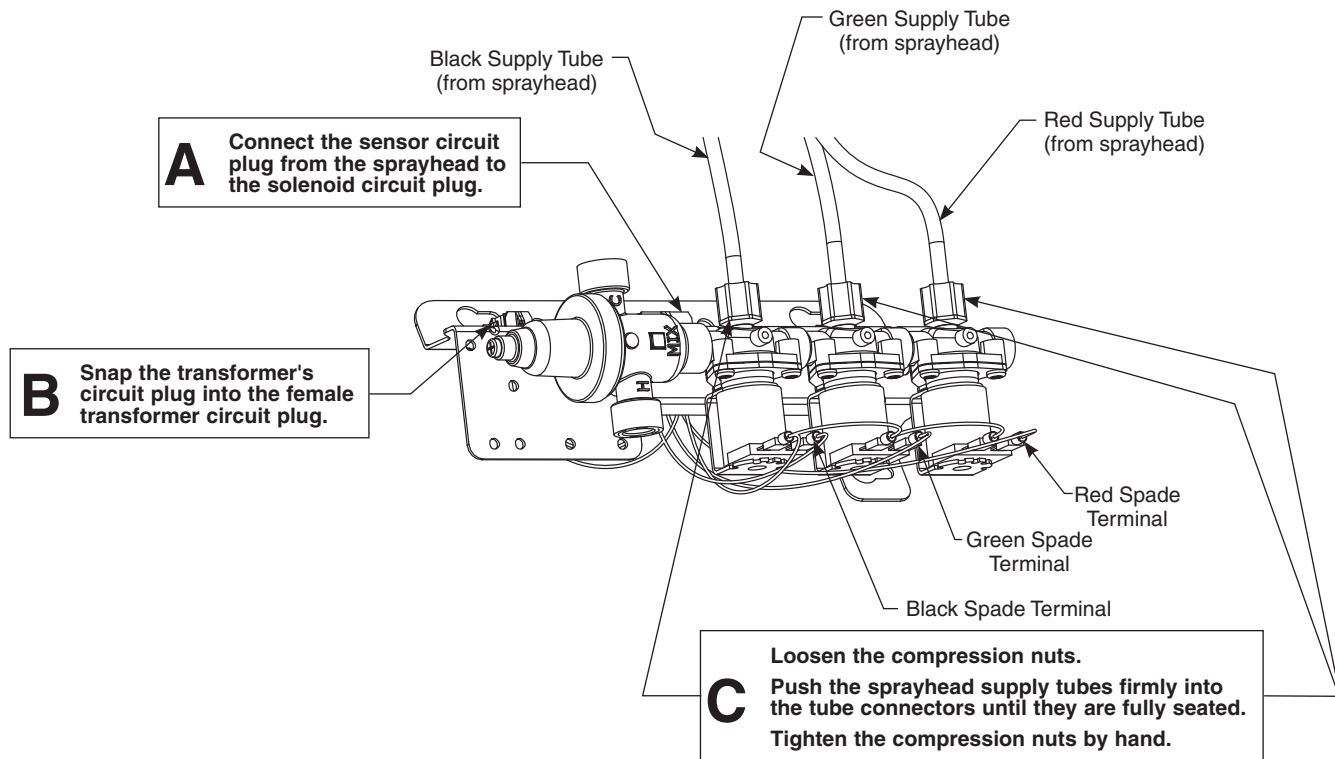

8 Adjust the Temperature



This valve is NOT factory preset. Upon installation, the temperature of this valve must be checked and adjusted to ensure delivery of a safe water temperature. Water in excess of 110°F (43°C) may cause scalding.

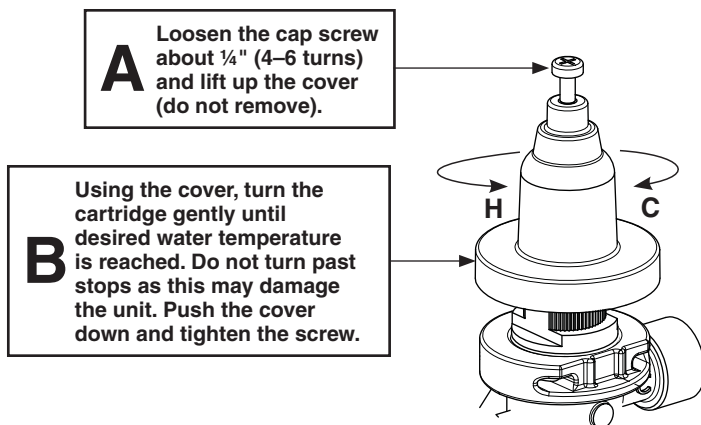

C Reinstall the valve bracket. Turn on the water supply and check for leaks. Turn on the electrical power to the electrical outlet and pass your hand in front of each station's sensor until all the air is purged from the lines and water is flowing smoothly. Reinstall the access panel.

START-UP NOTE: Wait two full minutes after making the power connection before using the lav. The sensors will take up to eight full minutes (while not in use) to adapt to the bowl if another object is detected during the two-minute start-up period.

Sensor assembly and solenoid valve access

- **To access sensors:** Remove the Phillips-head screws located in the bottom of the sprayhead body and lift the Terreon cover/shelf off.
- **To reinstall sprayhead cover/shelf:** Position the cover/shelf on the sprayhead body and secure it to the sprayhead body using the screws provided.

Sprayhead Components

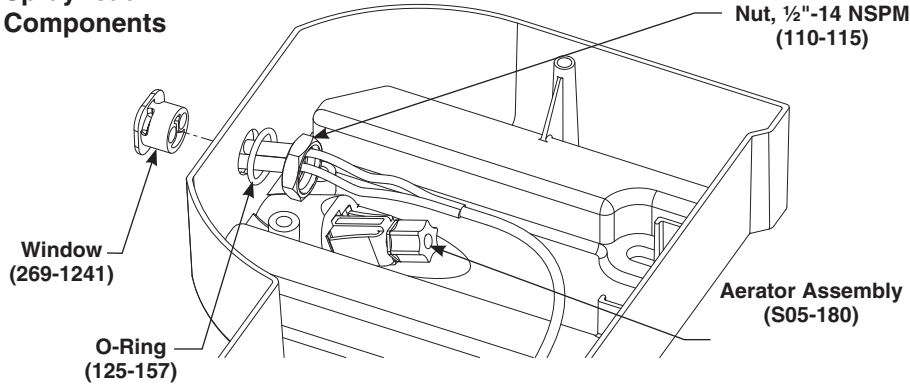

**INFRARED SENSOR
269-1608HP**

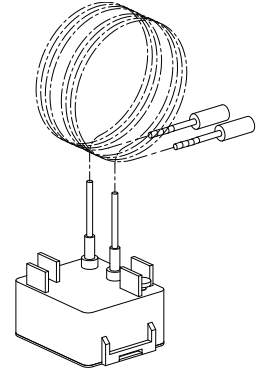

Troubleshooting – Solenoid Valve: Part nos. S07-067 (closed body) & S07-067A (thru body)



Turn off water supplies to the unit before troubleshooting.

| Item | Qty. | Part No. | Description |
|------|------|----------|-------------------------|
| 1 | 1 | 118-307 | Valve Body, ¼" Closed |
| 1 | 1 | 118-307A | Valve Body, ¼" Thru |
| 2 | 1 | 269-983 | Diaphragm |
| 3 | 1 | 269-577 | Armature |
| 4 | 1 | 269-578 | Spring |
| 5 | 1 | 269-1729 | Armature Housing |
| 6 | 1 | 269-1730 | Clamp, Armature Housing |
| 7 | 1 | 269-579 | Coil, Solenoid Valve |
| 8 | 3 | 160-447 | Screw, #8 x 5/8 |
| 9 | 1 | 125-165 | O-Ring, #2-013 |

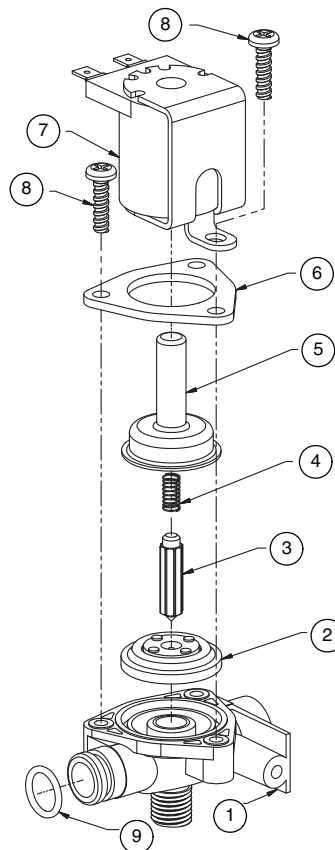

Repair Kit S65-113

| Item | Qty. | Description |
|------|------|-------------|
| 2 | 1 | Diaphragm |
| 3 | 1 | Armature |
| 4 | 1 | Spring |

| Problem | Cause | Solution |
|--|---|---|
| An individual operating station fails to shut off and drips. | Debris is trapped between the diaphragm and the valve seat. | <p>Remove debris between diaphragm and the valve seat.</p> <ol style="list-style-type: none"> 1. Remove the three #8 Phillips-head screws that hold the solenoid valve assembly together. Be careful not to lose the armature or spring. 2. Remove the diaphragm. Remove any particles that have been trapped between the diaphragm and the valve seat. Rinse off the diaphragm and inspect for damage. Make sure the center orifice and both small side orifices are open. 3. Reassemble in reverse order (do not overtighten the Phillips-head screws or the plastic valve body may crack). Tighten until the armature plate makes contact with the plastic body. 4. Reconnect the wiring. |
| An individual operating station fails to turn on. | A failed coil for the valve or loose electrical connection to the terminal. | <p>Test the station to determine the cause.</p> <ol style="list-style-type: none"> 1. Disconnect the wires from the coil of an adjacent valve. Disconnect the wires from the problem valve and reconnect to the adjacent valve. 2. Turn on electrical and water supplies to the unit. Pass your hand in front of the sensor of the problem station, and the adjacent station should turn on. <p>If the adjacent station turns on and cycles normally, replace the coil on the problem valve.</p> <p>If the adjacent valve fails to turn on, inspect the wires from the sensor cable and do the following:</p> <ul style="list-style-type: none"> • make sure there are no breaks and that the fully insulated disconnect terminals are firmly crimped in place; • turn off the electrical and water supplies; • reconnect to the adjacent valve and turn on the water supplies to the unit; • pass your hand in front of the sensor. If the station still fails to turn on, replace the sensor. |

Thermostatic Mixing Valve Troubleshooting

- ⚠** Before attempting to troubleshoot the valve or disassemble the components, check for the following conditions:
- If stop valves are used, make sure that they are fully open.
 - Make sure that the hot and cold inlet pipes are connected properly, and that there are no cross-connections or leaking stop valves.
 - Check the hot water heater output to make sure that it is at least 10° F above the set temperature.
- ✓** Be sure to close the appropriate shut-off valves prior to disassembly of the valve and reopen the valves after inspection and repair is complete.

| Problem | Cause | Solution |
|--|---|---|
| External leaks. | Damaged cartridge or O-rings. | Replace cartridge with part number 269-1927 |
| Improper water temperature or temperature fluctuation. | Hot water supply is not 10° above desired set point. | Increase hot water supply temperature |
| | Valve temperature is not properly set. | Adjust the temperature as shown on page 10, step 8. |
| Limited water flow. | Dirt and debris have built up in the valve or strainer. | <p>1. Check to make sure both hot and cold supplies are connected to the Navigator mixing valve and that they have water flow.</p> <p>2. Remove cover and U-clip. Remove the cartridge and clean the strainer. It is not required to grease cartridge, however if desired, use silicone grease only. Do not use grease on check valves.</p> |

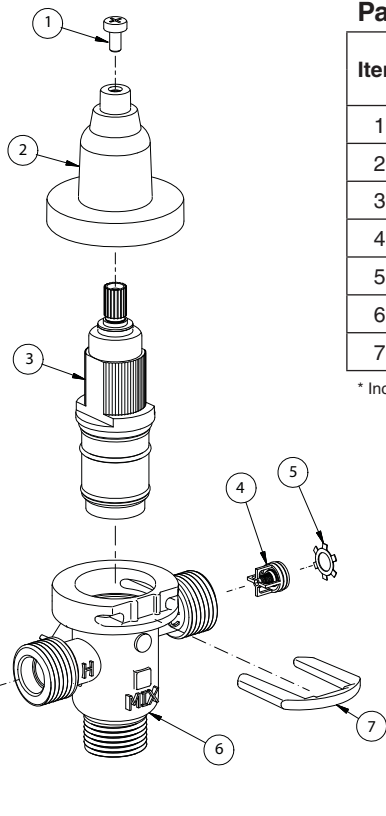

Parts List

| Item | Part No. | Description | Quantity | | |
|------|----------|------------------------|----------|-----------|------------|
| | | | S59-4000 | S59-4000A | S59-4000BY |
| 1 | 160-463 | Cap Screw | 1 | 1 | 1 |
| 2 | 107-582 | Cover | 1 | 1 | 1 |
| 3 | 269-1927 | Thermostatic Cartridge | 1 | 1 | 1 |
| 4 | 198-014 | Check Valve* | 2 | 2 | 2 |
| 5 | 132-051 | Retaining Ring* | 2 | 2 | 2 |
| 6 | 118-319 | Valve Body | 1 | 1 | 1 |
| 7 | 146-079 | U-Clip | 1 | 1 | 1 |

* Included with Prepack S65-326

Tempered Line Adapter Option Part no. S39-804

(replaces S59-4000 if tempered line is used)

Strainer
(173-028)

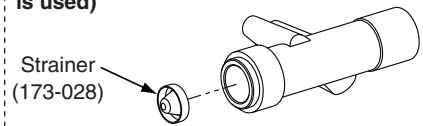

Stop Valve Troubleshooting

| Problem | Cause | Solution |
|---|--|---|
| Water dribbles or does not flow from the sprayhead. | Stop Valves may not be functioning properly. | <ol style="list-style-type: none"> 1. Close the stops and inspect the valves that supply water to the lavatory system. 2. Inspect the stop valves to see that they have been properly installed. |
| Sprayhead delivers ONLY hot OR cold water. | Stop Valves may not be functioning properly. | <ol style="list-style-type: none"> 1. Close the stops and inspect the valves that supply water to the lavatory system. 2. Inspect the stop valves to see that they have been properly installed. 3. Inspect the thermostatic mixing valve for proper installation and connection to hot and cold supplies. |

Cleaning and Maintenance for Terreon®

Material Description: Terreon is an NAHB-certified densified solid surface material composed of polyester resin and is resistant to chemicals, stains, burns and impact. Surface damage can be easily repaired with everyday cleansers or fine grit abrasives.

Routine Cleaning: Clean daily or as often as conditions require using a standard commercial or household cleaner such as Formula 409® or Windex®.

Stubborn Stains: Remove tough stains with Ajax®, Comet®, or Soft-Scrub® and a green Scotch-Brite® pad or lightly sand in a circular motion with 240 grit wet/dry sandpaper. The finish can be renewed with a maroon Scotch-Brite pad.

Special Situations for Terreon Material

Scratches: Remove scratches with a green Scotch-Brite pad. The finish can then be renewed with a maroon Scotch-Brite pad, followed by a white Scotch-Brite pad or 30-micron sandpaper.

Hard Water Deposits: Remove hard water deposits with a mild solution of vinegar and water. Always rinse the unit thoroughly after cleaning.

Restoring the surface: Use Hope's® Solid Surface cleaner and polish to refresh and protect the Terreon Solid Surface material. Bradley recommends additional care and maintenance for the darker colored Terreon. For complete instructions on this additional maintenance, visit bradleycorp.com.

 **Do not use strong acid or alkaline chemicals and cleansers to clean Terreon. If these chemicals come in contact with the surface, wipe them off immediately and rinse with soapy water. Avoid contact with harsh chemicals such as paint remover, bleach, acetone, etc. Avoid contact with hot pans and objects.**

Repair Kits: Terreon repair kits are available. Contact your Bradley representative or distributor for part numbers and pricing. Repair kits are made to order and have a shelf life of 30 days.

 *Terreon® is a unique, cast solid surface material. Aggregate flow and distribution as well as shades of color can vary from product to product creating natural characteristics.*

Brand Names

Use of brand names is intended only to indicate a type of cleaner. This does not constitute an endorsement, nor does the omission of any brand name cleaner imply inadequacy. Many products named are regional in distribution, and can be found in local supermarkets, department and hardware stores, or through your cleaning service. It is emphasized that all products should be used in strict accordance with package instructions.

Fill Soap Dispenser



The soap valve will dispense vegetable/coconut oil liquid soaps, synthetic detergents, viscous lotion soaps, and antiseptic solutions. A 10-15% concentration is recommended for vegetable or coconut oil liquid soaps. Before filling, rinse out each soap tank with hot water to remove packing dust. Shake water out thoroughly and allow to dry. **DO NOT OVERFILL!**

Soap Tank Kits

| S65-291 (Gray) includes: | S65-291A (Putty) includes: | S65-291B (Coal) includes: |
|--------------------------------|----------------------------------|---------------------------------|
| Gray Tank w/Valve (S11-220) | Putty Tank w/Valve (S11-220A) | Coal Tank w/Valve (S11-220B) |
| Leaf Spring (S39-350) | Leaf Spring (S39-350) | Leaf Spring (S39-350) |
| Screw (160-385) | Screw (160-385) | Screw (160-385) |

Soap Valve Repair Kit (S65-258) (includes Nut, Spring, Washer and Plunger)



Leaf Spring will engage when soap tank is pushed into place.

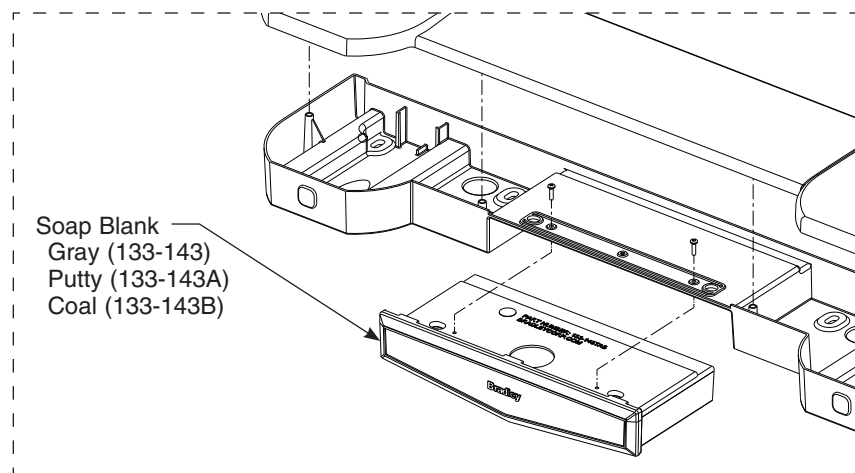
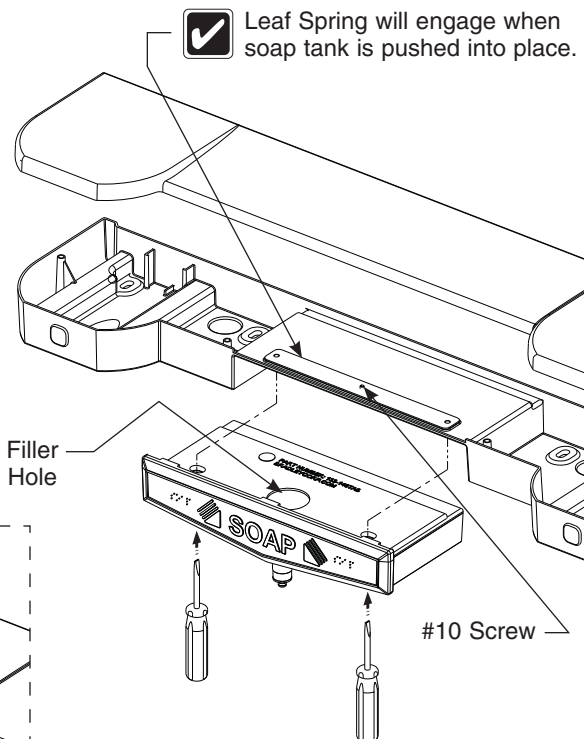

Clean Soap Dispenser



Do not use abrasive cleansers to clean the soap tank. Abrasive cleaners can damage the surface.

Regular cleaning of the soap dispenser is recommended to ensure optimum performance and maximum service life. Cleaning the soap dispenser monthly to remove soap residue, dirt, and other accumulations should become a regular part of your washroom cleaning routine and general maintenance program.

Clean exterior: Use warm water and soap to clean the exterior of the soap dispenser. Dry with a soft cloth.

Clean interior: Inspect the interior of the tank for residue or coagulation of soap. If necessary, clean the tank according to the following procedure:

1. Pour out any remaining soap in the tank.
2. Full the tank half-full of hot water and shake the tank to dislodge the soap residue.
3. Empty the water from the container and repeat steps 1 and 2 until the soap container is clean.



If rinsing alone does not remove the soap residue, place a small chain (24 inches long) into the tank with hot water and shake the container until the chain dislodges the residue. Then remove the chain and rinse out the tank.

Clean internal components: Pump hot water through the soap dispenser until a clean flow of water comes out of the valve.



To change soap, pour out all of the soap from the dispenser and rinse with hot water several times until all residue is removed. Pump the valve until clean water appears. Rinse the dispenser with ethyl alcohol; air dry before refilling.